

# ACm Centrifugal Pump



## Application

- Can be used to transfer clean water or other liquids similar to water in physical and chemical properties
- Suitable for industrial use and urban water supply, pressure boosting for high buildings and fire fighting, garden irrigation, long-distance water transfer, heating ventilation and air controlling, circulation and pressure boosting for cold and hot water, and supporting equipment etc.

## Pump

- Cast iron pump body and support under special anti-rust treatment
- AISI 304 shaft
- Max. liquid temperature: +60°C
- Max. suction: +8 m

## Motor

- C&U bearing
- Motor with copper winding
- Built-in thermal protector for single phase motor (≤1.5 kW)
- Insulation class: F
- Protection class: IPX4
- Max. ambient temperature: +40°C
- IE 2 motor (Three phase, power ≥ 0.75kW)

## Identification Codes

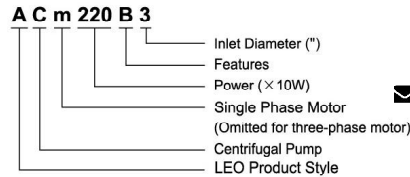

## Hydraulic Performance Curves

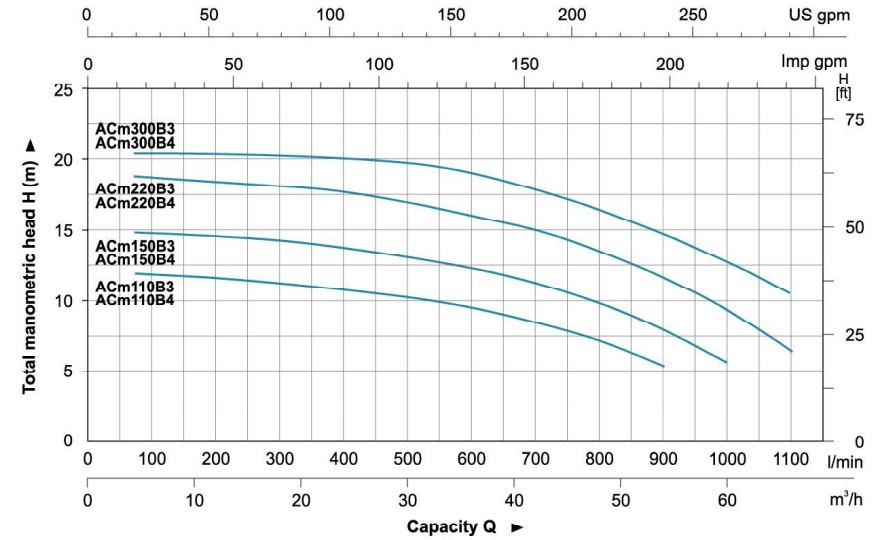

## Materials Table

No.	Part	Material
1	Filling plug	HPb59-1
2	Pump body	HT200
3	Impeller	Brass
4	O-ring	NBR
5	Mechanical seal	Carbon/Ceramic
6	Bracket cover	HT200
7	Oil seal	
8	Support	HT200
9	Bearing	
10	Rotor	
11	Terminal board	PC
12	Capacitor	
13	Terminal box	PA6-GF25
14	Stator	
15	Rear cover	ZL102
16	Fan	PP
17	Fan cover	PP

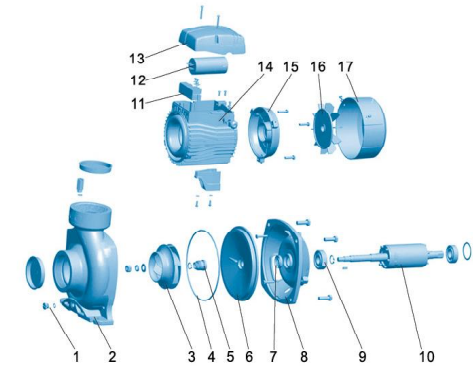

## Technical Data

MODEL	POWER		Q (m³/h)													
	Single Phase	Three Phase	kW	HP	0	12	18	24	30	36	42	48	54	60	66	71
ACm110B3	AC110B3	1.1	1.5	H (m)	12.5	12.5	12.1	11.5	10.5	9.5	8.4	7.1	5.5	-	-	-
ACm110B4	AC110B4	1.1	1.5		12.5	12.5	12.1	11.5	10.5	9.5	8.4	7.1	5.5	-	-	-
ACm150B3	AC150B3	1.5	2		14.5	14.3	14	13.5	12.8	12	11.2	9.9	8.4	6	-	-
ACm150B4	AC150B4	1.5	2		14.5	14.3	14	13.5	12.8	12	11.2	9.9	8.4	6	-	-
ACm220B3	AC220B3	2.2	3		17.5	17.3	17.1	16.5	16	15.2	14.2	13.2	11.7	10	7.2	-
ACm220B4	AC220B4	2.2	3		17.5	17.3	17.1	16.5	16	15.2	14.2	13.2	11.7	10	7.2	-
ACm300B3	AC300B3	3	4		20	19.8	19.6	19.5	19	18.3	17.5	16.2	14.6	13	11.5	10
ACm300B4	AC300B4	3	4		20	19.8	19.6	19.5	19	18.3	17.5	16.2	14.6	13	11.5	10

## Dimension

Model	DN1	DN2	L (mm)	W (mm)	H (mm)	L <sub>1</sub> (mm)	W <sub>1</sub> (mm)	H <sub>1</sub> (mm)
ACm110B3	3"	3"	386	230	295	68	180	120
ACm110B4	4"	4"	393	230	295	75	180	120
ACm150B3	3"	3"	386	230	295	68	180	120
ACm150B4	4"	4"	393	230	295	75	180	120
ACm220B3	3"	3"	453	230	295	68	180	120
ACm220B4	4"	4"	460	230	295	75	180	120
ACm300B3	3"	3"	453	230	295	68	180	120
ACm300B4	4"	4"	460	230	295	75	180	120

## Package Information

Model	GW (Kgs)	L (mm)	W (mm)	H (mm)	Quantity (PCS/20 TEU)
ACm110B3	26.3	433	255	332	684
ACm110B4	29.5	433	255	332	675
ACm150B3	27.2	433	255	332	684
ACm150B4	30.4	433	255	332	655
ACm220B3	34.8	522	288	331	510
ACm220B4	38	522	288	331	496
ACm300B3	37.3	522	288	331	506
ACm300B4	40.5	522	288	331	467

